

**Hydraulic Performance Curves**

<b>LPP65</b>	<b>Rated speed: 2900r/min</b>	<b>Max. working pressure: 16bar</b>
--------------	-------------------------------	-------------------------------------

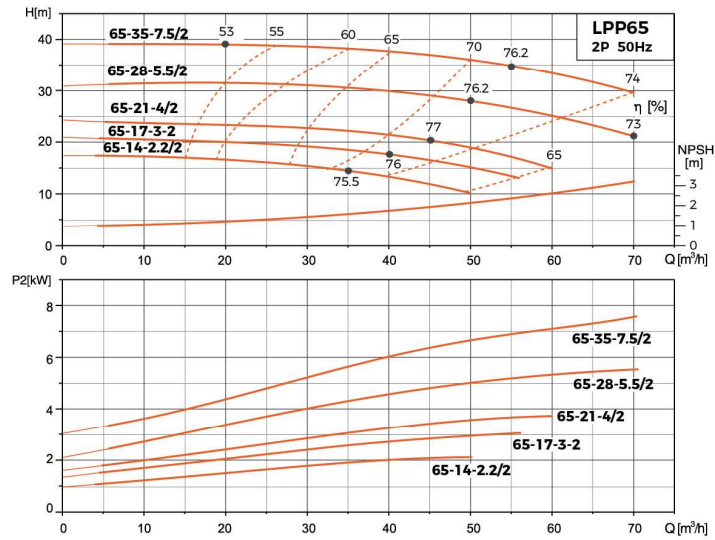

**Dimension**

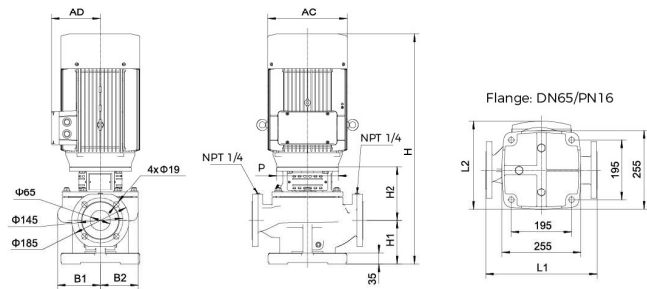

Model	L1 (mm)	L2 (mm)	H (mm)	H1 (mm)	H2 (mm)	B1 (mm)	B2 (mm)	P (mm)	AD (mm)	AC (mm)
LPP65-35-7.5/2	360	265.5	815	140	176	138	123	Φ200	175	254
LPP65-28-5.5/2	360	265.5	815	140	176	138	123	Φ200	175	254
LPP65-21-4/2	360	261	729	140	191	138	123	Φ160	143	210
LPP65-17-3/2	360	261	674	140	191	138	123	Φ160	120	186
LPP65-14-2.2/2	360	261	651	140	191	138	123	Φ140	128	164

**Hydraulic Performance Curves**

<b>LPP65</b>	<b>Rated speed: 2950r/min</b>	<b>Max. working pressure: 16bar</b>
--------------	-------------------------------	-------------------------------------

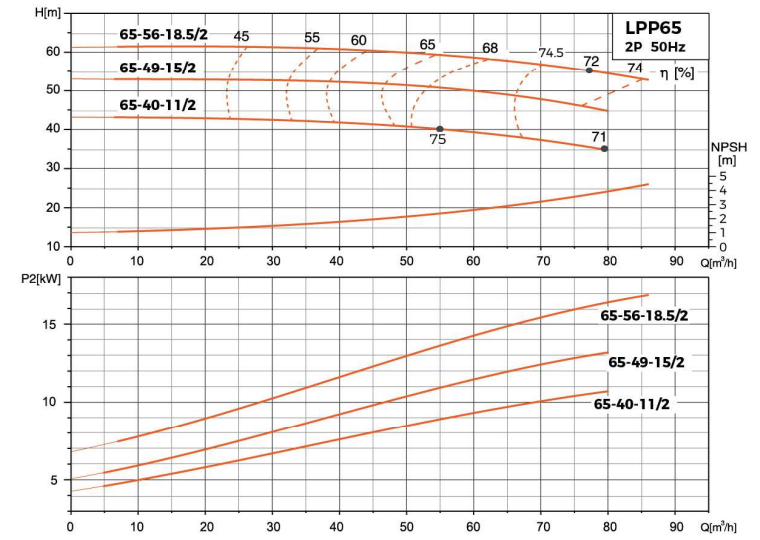

**Dimension**

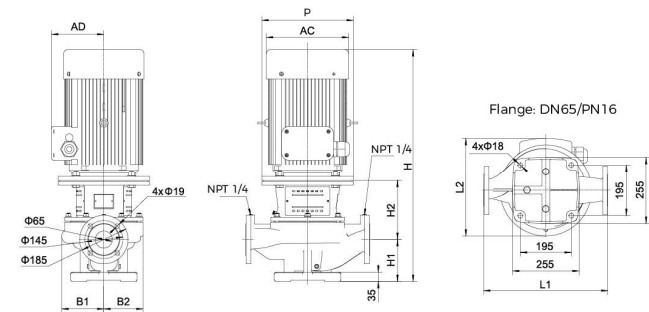

Model	L1 (mm)	L2 (mm)	H (mm)	H1 (mm)	H2 (mm)	B1 (mm)	B2 (mm)	P (mm)	AD (mm)	AC (mm)
LPP65-56-18.5/2	475	415	930	160	226	161	145	Φ350	283	330
LPP65-49-15/2	475	320	886	160	226	161	145	Φ350	283	330
LPP65-40-11/2	475	320	886	160	226	161	145	Φ350	283	330