

Hydraulic Performance Curves

LPP125	Rated speed: 1480r/min	Max. working pressure: 10bar(Optional 16bar)
--------	------------------------	--

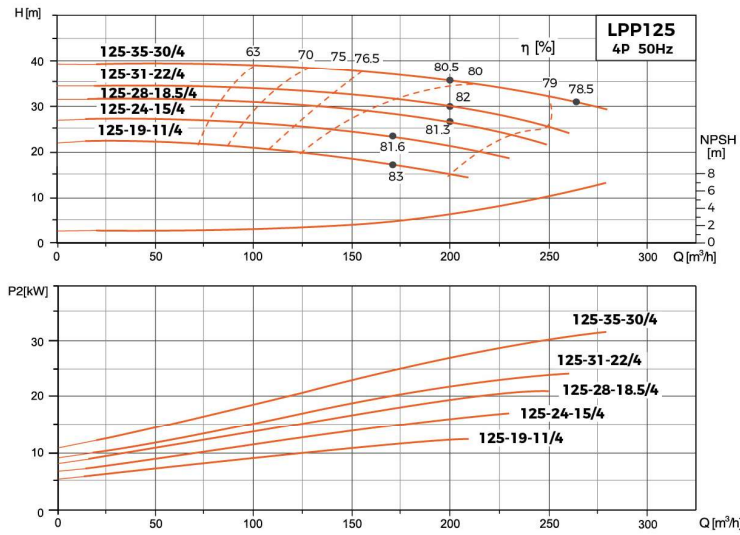

Dimension

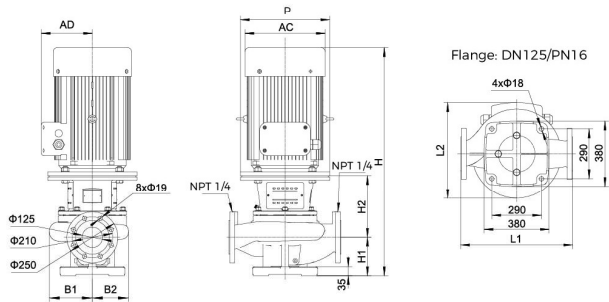

Model	L1 (mm)	L2 (mm)	H (mm)	H1 (mm)	H2 (mm)	B1 (mm)	B2 (mm)	P (mm)	AD (mm)	AC (mm)
LPP125-35-30/4	800	533	1192	250	280	265	228	Φ400	305	420
LPP125-31-22/4	800	508	1145	250	275	265	228	Φ350	280	380
LPP125-28-18.5/4	800	508	1105	250	275	265	228	Φ350	280	380
LPP125-24-15/4	800	493	1069	250	275	265	228	Φ350	283	330
LPP125-19-11/4	800	493	1025	250	275	265	228	Φ350	283	330

Hydraulic Performance Curves

LPP125	Rated speed: 2950r/min	Max. working pressure: 16bar
--------	------------------------	------------------------------

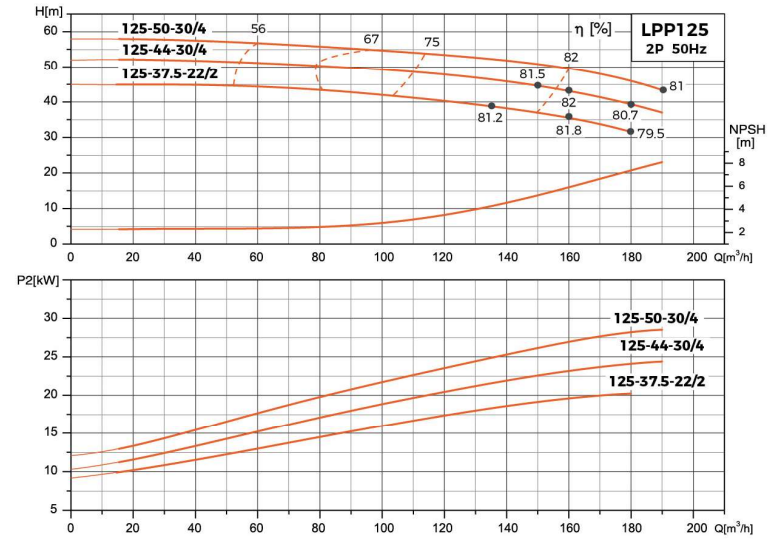

Dimension

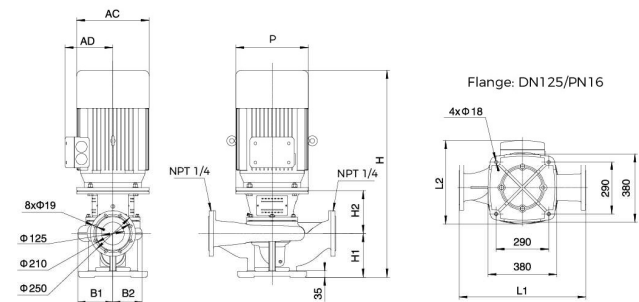

Model	L1 (mm)	L2 (mm)	H (mm)	H1 (mm)	H2 (mm)	B1 (mm)	B2 (mm)	P (mm)	AD (mm)	AC (mm)
LPP125-50-30/2	700	515	1137	240	235	193	161	Φ400	305	420
LPP125-44-30/2	700	515	1137	240	235	193	161	Φ400	305	420
LPP125-37.5-22/2	700	470	1048	240	228	193	161	Φ350	280	380