

Hydraulic Performance Curves

LPP80	Rated speed: 1480r/min	Max. working pressure: 16bar
--------------	-------------------------------	-------------------------------------

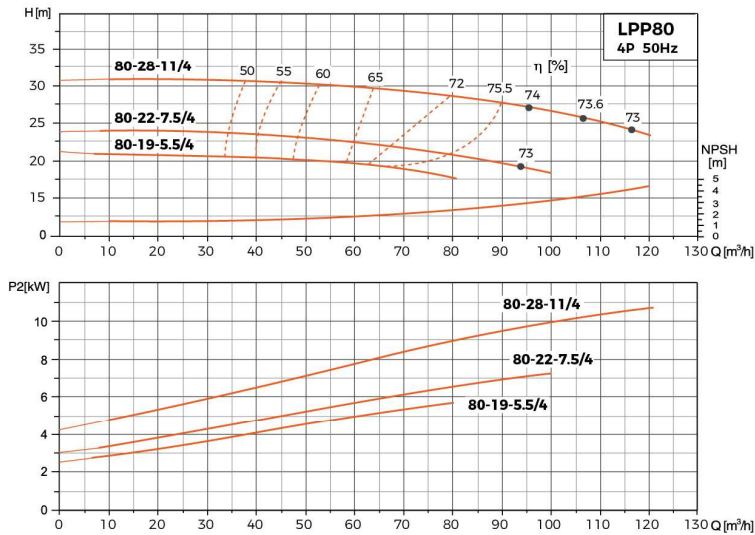

Dimension

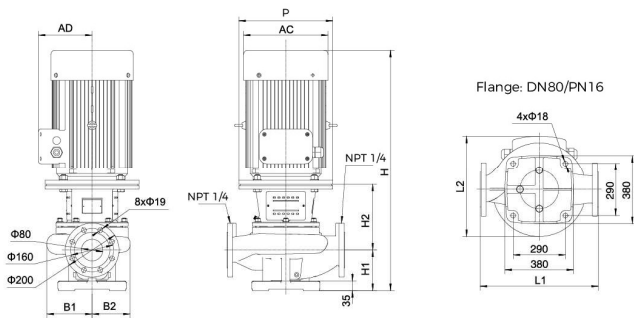

Model	L1 (mm)	L2 (mm)	H (mm)	H1 (mm)	H2 (mm)	B1 (mm)	B2 (mm)	P (mm)	AD (mm)	AC (mm)
LPP80-28-11/4	620	442	937	175	262	224	218	Φ350	283	330
LPP80-22-7.5/4	620	442	906	175	232	224	218	Φ300	175	254
LPP80-19-5.5/4	620	442	906	175	232	224	218	Φ300	175	254

Hydraulic Performance Curves

LPP100	Rated speed: 2950r/min	Max. working pressure: 10bar(Optional 16bar)
---------------	-------------------------------	-----------------------------------------------------

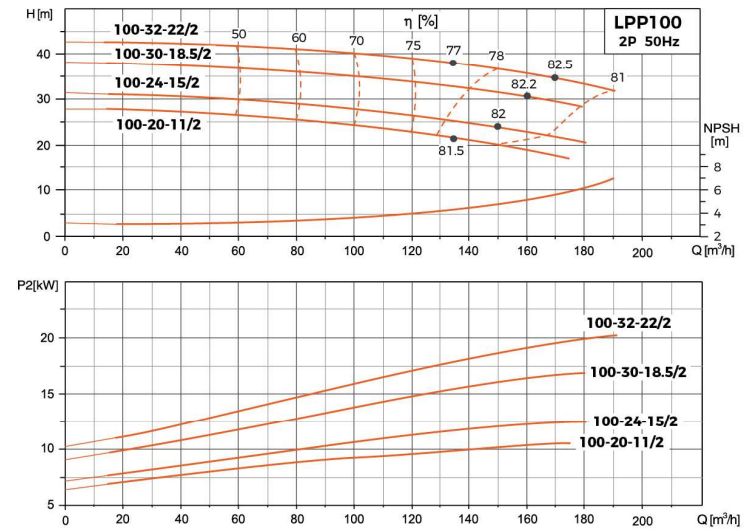

Dimension

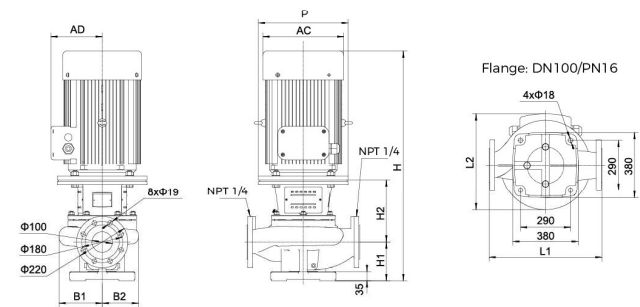

Model	L1 (mm)	L2 (mm)	H (mm)	H1 (mm)	H2 (mm)	B1 (mm)	B2 (mm)	P (mm)	AD (mm)	AC (mm)
LPP100-32-22/2	500	470	1027	175	272	183	144	Φ350	280	380
LPP100-30-18.5/2	500	415	991	175	272	183	144	Φ350	283	330
LPP100-24-15/2	500	327	947	175	272	183	144	Φ350	283	330
LPP100-20-11/2	500	327	947	175	272	183	144	Φ350	283	330